

Design and Analysis of Prototype Tesla Turbine for Power Generation Applications

I. Zahid¹, A. Qadir², M. Farooq³, M. A. Zaheer⁴, A. Qamar⁵, H. M. A. Zeeshan⁶

¹Mechanical Engineering Department, University of Sarghodka, Pakistan

^{2,4,6}Mechanical Engineering Department, The University of Lahore, Pakistan

^{3,5}Mechanical Engineering Department, UET Lahore, Pakistan

¹imranxahid@gmail.com

Abstract-The objective of the present research is to examine the potential benefits of Tesla Disk Turbine (TDT), a harmless mean of energy conversion from high pressure non-polluting fluid (compressed air, water & steam) to a form of energy e. g. electricity, mechanical power which can be used in various applications. A prototype model of TDT was designed and different experiments were performed with various pressure ranges of compressed air. Theoretical sound (boundary layer theory, adhesion, and viscosity), design, material selection, fabrication, efficiency, power output, advantages, limitations, its applications have been discussed. This model can alternatively be used in different applications of power generation as replacement of batteries & generators. Steam, water and other medium can also be part of this technology by adapting this turbine for large scale energy production. The result obtained from the current research could be utilized as a guide for the further design and operation of the industrial system.

Keywords-Axial flow disc; Boundary layer theory; Compressed air; Flow efficiency; Tesla Turbine.

I. INTRODUCTION

The TESLA, bladeless turbine, uses smooth circular discs instead of vanes and it is placed inside the construction cabinet. Principle of this turbine comes from adhesion and viscosity (Boundary layer effect) [i].

The turbine consists of two main parts, the rotor

and the stator [ii]. The rotor comprises asset of discs placed on the shaft. The stator is the housing of the rotor. A nozzle represents to direct the high speed fluid flow towards the disk's periphery. The fluid flows into the turbine through a tangential inlet and enters the system of spaces in the line of disks. By attrition of the fluid and the disks, the turbine runner is made to rotate. The centrifugal power is affected through the rotation on the turbine rotor between the discs provide its long spiral track [iii]. With growing mechanical load on the turbine, the speed drops, the centrifugal power runs low and the liquid track turns more into the center. This enhances the flow capacity through the mechanism bigger [iv]. Also with the mechanical load off, the higher speed provides the greater centrifugal power. Due to the possible change in speed, the mechanism becomes flexible. Nikola Tesla claimed that total effectiveness of this turbine could reach upto 98% [iv]. Later on, different prototypes design models used compressed air and showed the total effectiveness round about 40% [v]. Numbers of properties of TDT were discussed in current studies. Unlike other conventional ways of power generation, it is environment friendly as it makes the use of non-polluting fluids such as compressed air, water, steam etc. As fluid drags the disc, depends on its viscosity and adhesion of the surface layer of fluid with disc. As the viscosity of these working fluids are close to each other, the bit difference is managed by other properties of fluid like adhesion Hence it is stated as the green energy source [vi]. Fig. 1 shows the implementation of tesla turbine as a green energy resource.

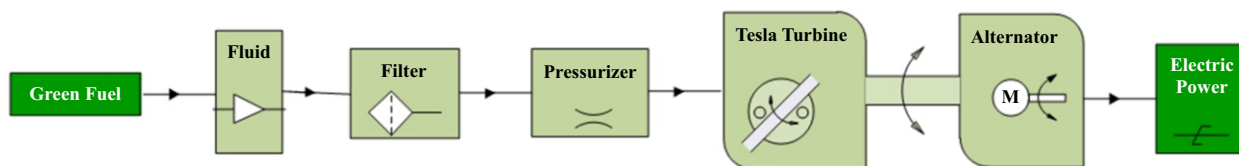

Fig. 1. Tesla Turbine Implementation as a non-conventional energy resource [VII]

Tesla Turbines finds its applications at certain places where the conventional turbine fails to operate as “it can be used to tap geothermal energy from underground salt-brine in locations all over the world” [viii]. It is a

highly efficient rotary engine which has an amazing power and simplicity. This is the sole high power turbine that can be fabricated in expensively using only some simple machining tools; hence it is operationally

advantageous over expensive machines [ix]. Roman in proposed analytical solution method to achieve main objective of design analysis of Tesla Turbine [x]. Krishnan further modified and presented incompressible small as well as medium scale turbine and calculated useful results using ANSYS simulation [xi]. Rice worked for the better performance of Tesla turbine but his experiments were computational base. Guha, Hoya and Deam also presented computational model for small to large scale but could not present analytical solution for the performance of Tesla Turbine [xii-xiv]. After all Carey achieved useful results using analytical solution [xv].

In the present research, the model of tesla turbine has been used for the different applications of power generation as replacement of batteries & generators. For upgraded energy production system, steam, water and other medium could be used for this technology. The result obtained from the current research could be utilized as a guide for the further design and operation of the industrial system.

II. MATERIAL AND METHODS

A. Material Selection

The most important part of the tesla turbine is the rotor (shaft discs) and the nozzle. Material selection for these parts is of the extreme importance. Table 1 illustrates the various elements of tesla turbine. Ten aluminum discs with 9 spacers of 0.5mm & 16 washers of 5/16" were used as a series of discs in rotor of tesla turbine.

TABLE I
PARTS OF TESLA TURBINE MODEL AND QUANTITY

Parts	Quantity
Plexi glass Sheet	2
Collars	2
Aluminum Shaft	1
Ballbearingsinnerdia1.5cm	2
7"dia&5"lengthplasticpipe	1
5/16"dianutsandbolts	8
Cylinder for storing compressed air	1
Pressure gages with valves(inlet, outlet)	2
Nozzle with control flow valve	1
Rubber hose to supply air	1

Variety of advance materials was used to get control over extreme centrifugal forces inherent to the turbine, such as titanium-impregnated plastic, carbon-fiber and Kevlar-reinforced discs. In present model stainless steel was used for discs, aluminum for collar,

brass for nozzle, steel and aluminum for shaft. Table 2 shows the size of different parts of tesla turbine based on specific applications.

TABLE II
PARTS AND SIZE OF TESLA TURBINE MODEL

Parts	Size
Turbine diameter	100mm
Disk diameter	6 inches
Disk thickness	2 mm
Disk gap	1.2mm
Number of disks	10
Over base size	(113*185)mm
Total Weight	1420gapprox.
Turbine length (Ex Generator+Mounts)	75mm

B. Design of Tesla Turbine

The important criterion used in the tesla turbine was the designing of rotor, shaft, stator, collarand nozzle. In rotor's designing, a number of discs with same diameter (6 inch) and thickness (2mm) were mounted on a shaft and fixed with a very fine spacing (0.3-0.5mm) between each two. The nozzle slot, compared to the overall width of the rotor, was narrower i.e. the number of the active discs must be less in number than the total discs. For this case turbine with 25 discs, have 23 active discs including the disks with thicker ends. In order to attain more efficiency and overcome losses, nozzle with platinum chamber can be experimented, briefly the geometry of the nozzle can be changed using an interchangeable nozzle insert. As a design compromise it was necessary that the nozzle incorporated a 90° bend just before the exit plane. Using same strategy for inlet, losses could be controlled. The Propelling fluid get pass the outer most active discs. The assembly of rotor was housed inside a cylindrical stator, or within the stationary part of the turbine. In order to house the rotor, the interior format diameter was slightly larger in size than the discs of rotor. Ball bearing for the shaft at each end of the stator was used. Two inlets were contained by the stator, in which nozzles were inserted.

C. Tesla Turbine Prototype

A Tesla Turbine prototype was designed as shown in Fig. 2. This prototype model consists of various parts such as stator, stator outlets, rotor discs, exhaust port and shaft.

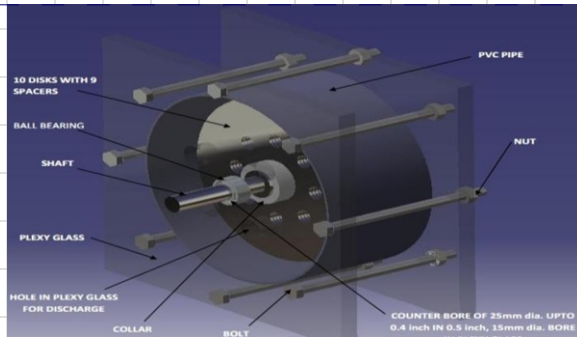

Fig. 2. Prototype Model of Tesla Turbine

D. Working Principle

The principle of Boundary Layer (BL) was followed for the working of Tesla Turbine (TT). According to this principle, molecules which are right next to the surface, stick to the surface as the fluid moves past each disc surface. Those molecules which follow the surface, stick to it and are slowed down in their collision to the molecules stuck to it. These molecules in results slowdown the flow which is just above them. As these molecules move away from these surfaces, the chances of their collisions are reduced with the object surface. Meanwhile, due to viscous forces, the molecules of the fluid resist for separation. These forces become prominent over the inertial forces. This will produce a pulling force that is transferred or moved to the disk, which causes the disk to rotate in the direction of fluid [xvi].

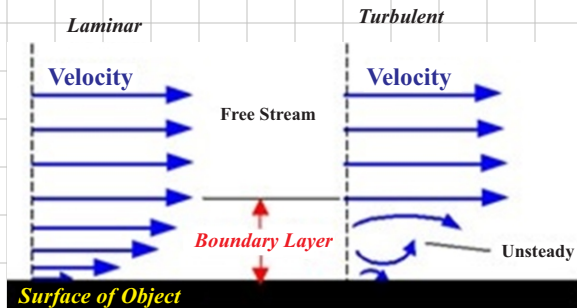

Fig. 3. Boundary Layer Effect [xvi]

The fluid enters the rotor disc spaces in turbulent regime and at the leading edge, starts the formation of boundary layer. Due to the dominating viscous forces,

flow is turned from turbulent to laminar. After the boundary layer build up, the forward transition to the turbulent occurs caused by the increase of velocity. The fluid accelerates in the radial direction and the thickness of the boundary layer decreases. Hence the inertial forces pre dominant and turbulence is expected to increase but with acceleration, the flow current in the turbulent boundary layer became extended and the vortices is dissipated through the viscous effects [xvi].

High speed fluid from the injection nozzle enters the inter-disk spacing and whirls around bending its flow towards the center of the shaft. It transfers some of its momentum of the rotor discs and ejects through the exhausts lots [v]. Fig. 4 shows the injection of fluid through stator inlets.

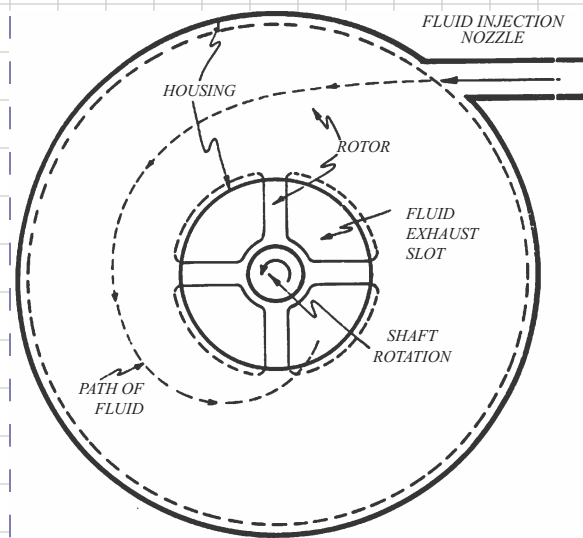

Fig. 4. Flow Path between Discs [xvii]

III. RESULTS AND DISCUSSION

The stator of Tesla turbine contains two or more inlets for nozzles. Through nozzles compressed air at about 272 kPa enters rotor discs results to spin rotor which was coupled with generator and gives output. A tube light of 40 watt was tested and different parameters such as voltage, current and power were observed.

TABLE III
POWER OBTAINED FROM TESLA TURBINE AT DIFFERENT SPEED

Pressure (Kpa)	Rotation (rpm)	Light (Watt)	Voltage (Volts)	Current (Amp)	Efficiency (%)	Power (Watts)
272	1000	40	11	1.5	58	16.5
272	1500	40	12	1.59	58	19.08
272	2000	40	14	1.65	58	23.1
272	2230	40	14	1.72	58	24.08

A. Power Outcome

Power obtained from tesla turbine was analyzed on different speeds. The result shows that the power increased with the increase of speed of rotor of the tesla turbine. There is direct relation between power and number of rotation. Fig. 5 shows the power at different speeds of the turbine. It can be observed that at 1000 rpm power obtained is 16.5 watt which increases linearly by increasing speed.

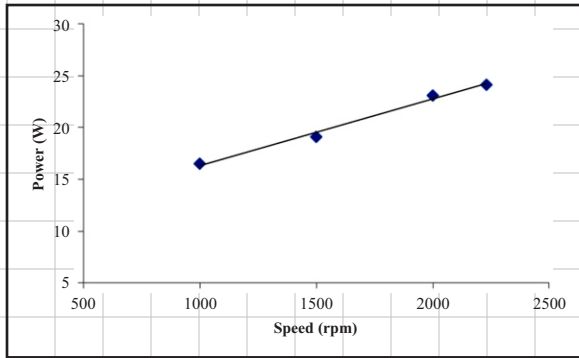

Fig. 5. Relationship between Power and rotation

B. Relation between Voltage & Speed

Fig. 6 depicts the relationship between the voltage and the speed. It is clear that there is almost linear relation between voltage and rpm. As speed decreases from 2230 to 1000 rpm voltage also declined from 14 to 11 volts. Solid line shows the actual behavior while dotted line shows linear relation. There is slight more variation of voltage comparatively at speed of 2000 rpm but still the relationship is linear.

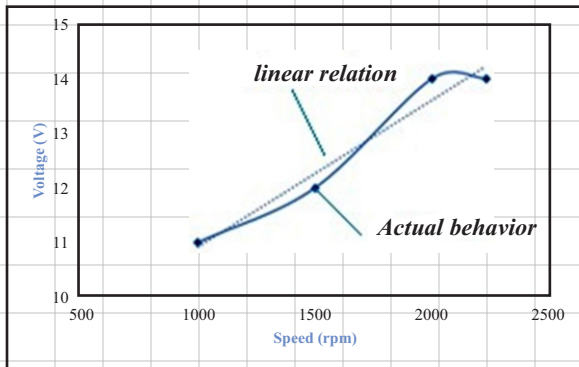

Fig. 6. Relationship between Voltage and rotation

C. Role of Current

The effect of the current with speed is also in accordance with the voltage. Thus also determined from the Ohm's law $V=IR$, where voltages are directly proportional to the current produced. It can be observed from Fig. 7 that at 2230 rpm the value of current that is measured is 1.72 ampere. Hence, the amount of current decreased as number of rpm decreased.

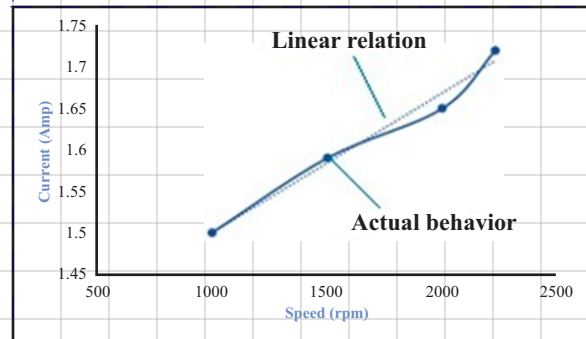

Fig. 7. Relationship between Current and rpm

C. Comparison of Efficiency among different turbines

Three key efficiency points of this turbine are inlet nozzle, disc geometry and the outlet. Disk geometry means the use of compatible material with quite perfect spacing and the accurate number of positions of dividers. Between discs, space must be from 0.032 inch to 0.125 inch. High torque and low horsepower was developed due to narrow spacing and vice versa. Two major functions are performed by inlet nozzle. It transforms gas pressure into the gas kinetic energy and converts the kinetic energy, in parallel streams, into the rotor (turbine disk pack). Figure 8 illustrates comparison of efficiencies of different turbines. The efficiency of bladed turbine is 22 percent and the efficiency of tesla turbine is 58 percent. Among all turbines, Tesla has maximum efficiency where as other turbines like Bladed, Gas Piston, Diesel and Fuel Cell are less in efficiencies of about 22%, 32%, 42% and 45% respectively. It clearly depicts that using Tesla disc turbines could bring more work output by utilizing maximum energy for running turbine. Conventional turbines are mostly reaction and impulse type or both. Tesla turbine is an unconventional turbine that uses fluid properties such as boundary layer and adhesion of fluid on series of smooth disks keyed to a shaft.

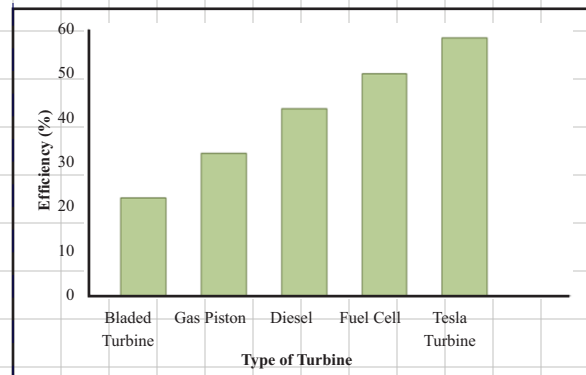

Fig. 8. Percentage Efficiency of Turbine

IV. COMPARATIVE ANALYSIS WITH CONVENTIONAL TURBINE USING CFD

Tesla turbine can generate power for variety of working media like Newtonian fluids, non-Newtonian fluids, mixed fluids, particle laden two-phase flows [XI]. In CFD, tesla turbines results are more clear and broad with lot of advantages seen. Comparative to traditional turbines, typical results of Tesla disc turbines are shown in Fig 9:

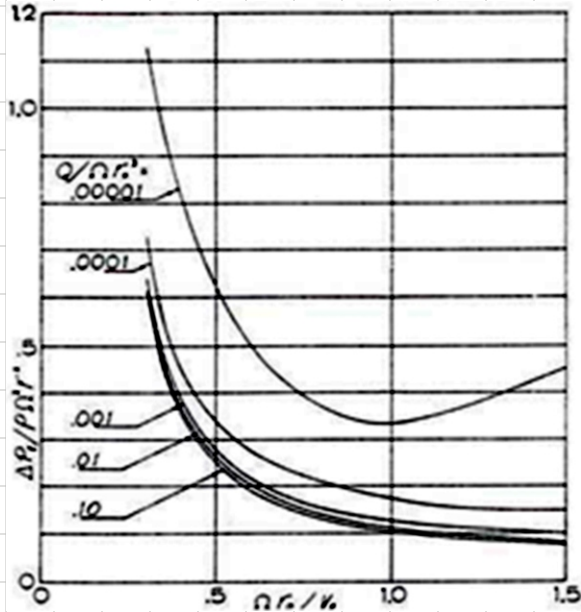

Fig. 9. Percentage Efficiency of Turbine

Whereas CFD analysis shows that it has better results. The three-dimensional flow field and the flow path lines within a Tesla disc turbine have been investigated analytically and computationally. The description of the flow field includes the three-dimensional variation of the radial velocity, tangential velocity and pressure of the fluid in the flow passages within the rotating discs.

Two domains were created in Solidworks2013. Rotating domain consisted of rotor assembly and the stationary domain consisted of outer casing with a simplified nozzle [xii]. Table 4 shows the meshing data for the domain created. Table 5 presents parameters selected for CFD analysis. Figure 6 shows the setup of two domains.

TABLE IV
MESHING DATA FOR DOMAINS OF TESLA TURBINE

Meshing Data	
Rotating Domain	
Nodes	483462
Elements	2011811
Stationary Domain	
Nodes	244141
Elements	1282278

TABLE V
PARAMETERS SELECTED FOR CFD ANALYSIS

Flow State	Transient
Boundary Conditions	Mass flow rate as inlet Atmospheric Pressure at outlet
Turbulence model	K-Epsilon
Mass flow rate	7.2 Kg/sec
Static atmospheric pressure	1 atm (Outlet condition)
Phase	Single(water)
RPM	800

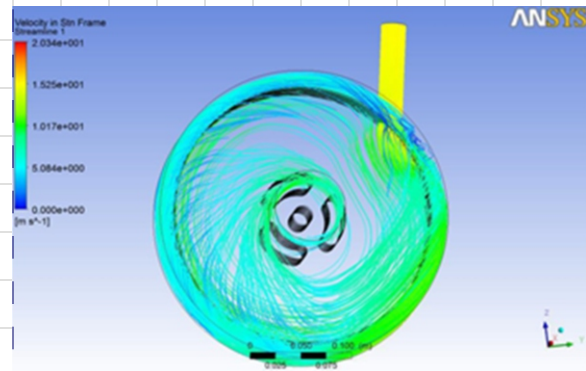

Fig.10. Two domains setup

V. CONCLUSION

In Present research the model of tesla turbine has been used for the different applications of power generation as replacement of batteries & generators. For upgraded energy production system, steam, water and other medium could be used for this technology. It is considered vital to introduce such apparatuses where efficiency is required higher In order to consume those energy resources in which more is the efficiency and less is the cost. This study evaluates that the tesla disc turbine compared to others, operates on high rpm with low vibrations and output is higher with lager velocities. Moreover it works on high velocity. This model can be used in different applications of power generation for the replacement of batteries & generators.Among his lesser-known inventions is a bladeless turbine. The Tesla Turbine differs from typical turbines in that instead of using curved blades like those of a windmill, it uses smooth, parallel disks placed evenly across a shaft, like CD's placed along a stick. By utilizing this phenomena, more modifications in future could bring this world out of the global energy crisis as well as it would let scientists developing systems with more efficiencies. It can replace steam turbines as it has more efficiency and could play an important role as in controlling world's pollution as it is one of the major clean sources of green energy.

REFERENCES

- [I] Tesla Turbines proposed for geothermal energy from American Antigravity.
- [ii] Tesla turbine builders' organization.
- [iii] V. D Romanin and V. P Carey. "An integral perturbation model of flow and momentum transport in rotating micro channels with smooth or micro structured wall surfaces". *Physics of fluid*, 23(2011)
- [iv] V. G. Krishnan, Z. Iqbal and M.M Maharbiz "A micro tesla turbine for power generation from low pressure heads and evaporation driven flows", pp. 1851-1854, (2011).
- [v] A. Guha and B. Smiley. "Experiment and analysis for an improved design of the inlet and nozzle in tesla disc turbines". pp. 261-277, 224 (2010).
- [vi] G. P. Hoya and A. Guha. "The design of test rig and study of performance and efficiency of a Tesla disc turbine". pp. 451-465, 223 (2009).
- [vii] R. T Deam, E. Lemma, B. Mace and R. Collins. "On scaling down turbines to millimeter size". 130(2008).
- [viii] V. Carey. "Assessment of tesla turbine performance for small scale Rankine combined heat and Power systems". 132 (2010).
- [ix] Boundary layer theory by Glenn Research Center.
- [x] Pneumatic Options Research Library: Design, construction and investigation of Tesla Turbine.
- [xi] Guha A, Smiley B. Experiment and analysis for an improved design of the inlet and nozzle in Tesla disc turbines. *Proc IMechE Part A: J Power Energy* 2010;224:261–77.
- [xii] Ladino, "Numerical Simulation of the Flow Field in a Friction-Type Turbine (Tesla Turbine)," Institute of Thermal Power plants, Vienna University of Technology.